

HIT CONNECTOR

Board-to-wire

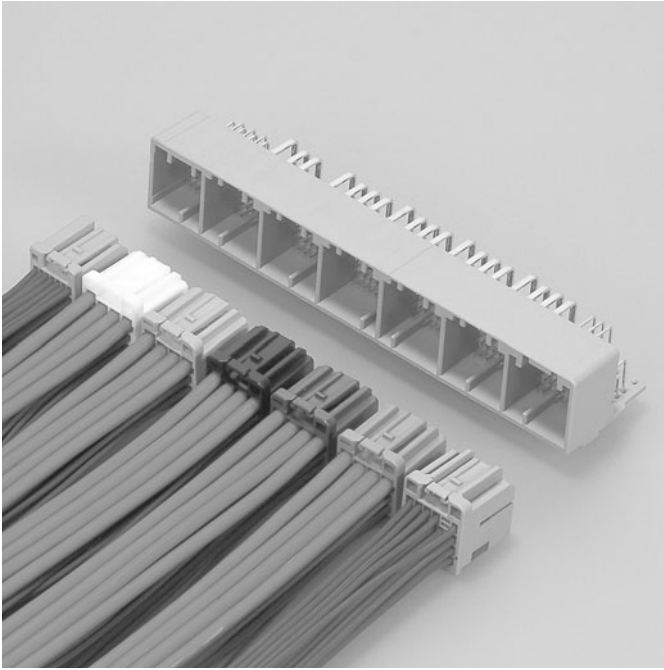

The HIT connector is multi-circuit and miniaturized for ECU for the automobile.
Female connector is divided into seven housings, and considers the ergonomics and workability.

Features

●Multi-circuit structure, Miniaturized

Current products available are up to 180-circuit. Although this connector is multi-circuit, it was miniaturized by narrow pitch. The insertion force in the mating operation of one time is decreased by block division structure.

●Reliability

It conforms to the automotive performance evaluation standard.

●Diversity

It is hybrid structures of using 0.64mm and 2.8mm terminals. Large current circuit is also available.

Specifications

- Current rating: 0.64 Terminal/ 5A AC, DC (0.5mm², Single circuit)
2.8 Terminal/ 25A AC, DC (5mm², Single circuit)
- Voltage rating: 14V AC, DC
- Temperature range: -40°C to +100°C
(including temperature rise in applying electrical current)
- Contact resistance: 0.64 Terminal;
Initial value/20mΩ max.
After environmental testing/20mΩ max.
2.8 Terminal;
Initial value/5mΩ max.
After environmental testing/5mΩ max.
- Insulation resistance: 20MΩ min.
- Withstanding voltage: 1,000V AC/minute
- Applicable wire: TXL/ AVSS/ CAVS
0.64 Terminal S/M; 0.3mm² to 0.85mm²
2.8 Terminal S/M/L; 0.85mm² to 5.0mm²

- * Compliant with ELV/RoHS.
- * Contact JST for details.

Female terminal

• 0.64 Female terminal SSS/SS

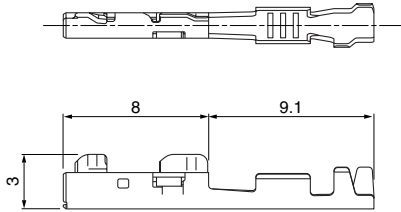

• 0.64 Female terminal S/M

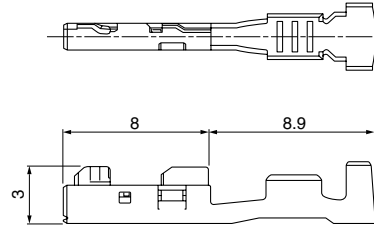

• 2.8 Female terminal S/M/L

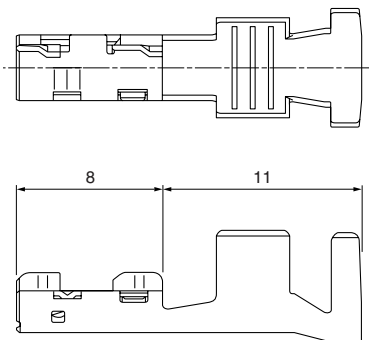

Terminal	Model No.	Applicable wire range		Q'ty/reel
		Conductor (mm ²)	Insulation O.D. (mm)	
0.64 SSS	SNAC3-A001T-M0.64	0.13	0.85	6,000
0.64 SS	SNAC3-A011T-M0.64	0.22 to 0.35	0.95 to 1.10	5,000
0.64 S	SNAC3-A021T-M0.64	0.3 to 0.5	1.4 to 1.8	5,000
0.64 M	SNAC3-A031T-M0.64	0.5 to 0.85	1.8 to 2.0	5,000
2.8 S	SNAC-A061T-M2.8	0.85 to 1.3	2.0 to 2.3	3,000
2.8 M	SNAC-A081T-M2.8	2.0 to 3.3	2.6 to 3.2	2,500
2.8 L	SNAC-A091T-M2.8	3.0 to 5.0	3.2 to 4.0	2,000

Material and Finish

Copper alloy, tin-plated (reflow treatment)

Female connector

• A Block

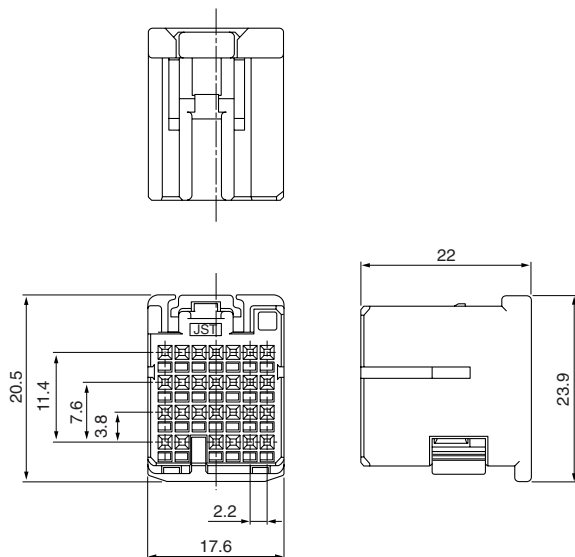

• B Block

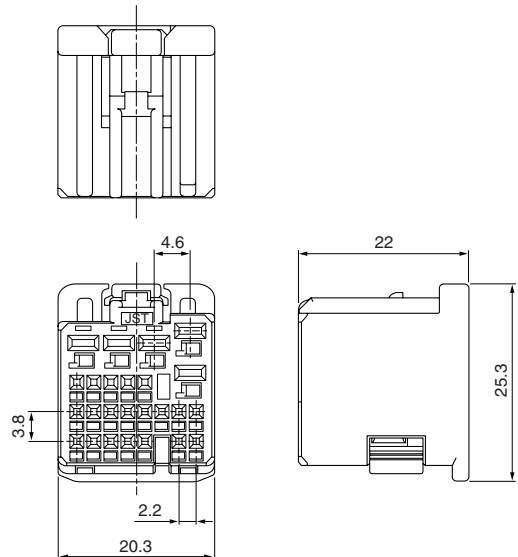

HIT CONNECTOR

Female connector

• C Block

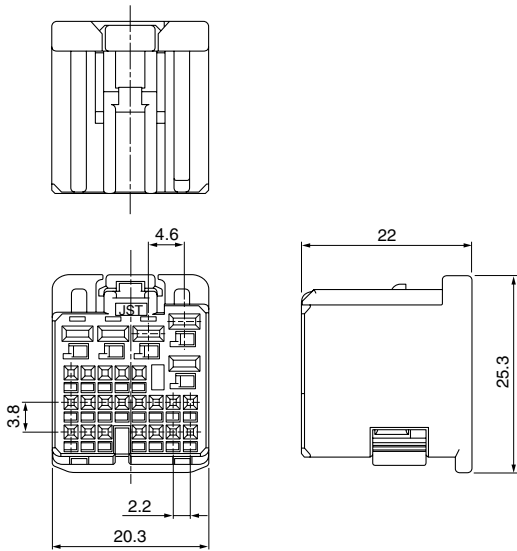

• D Block

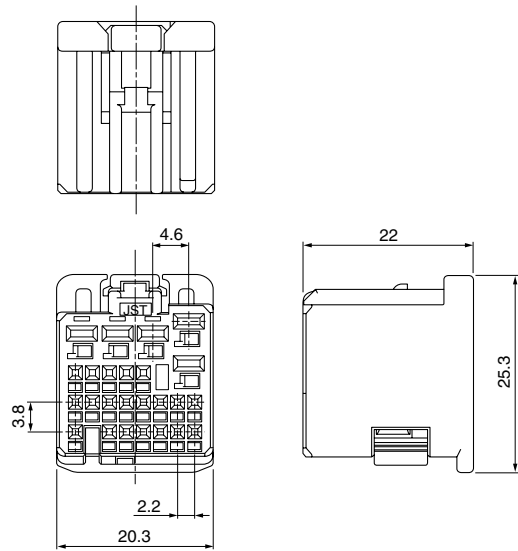

• E Block

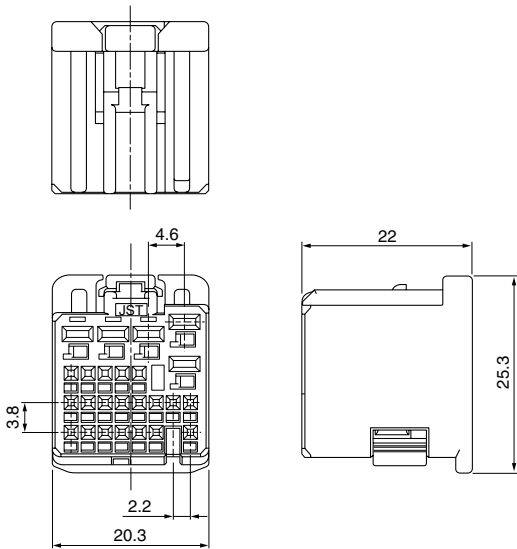

• F Block

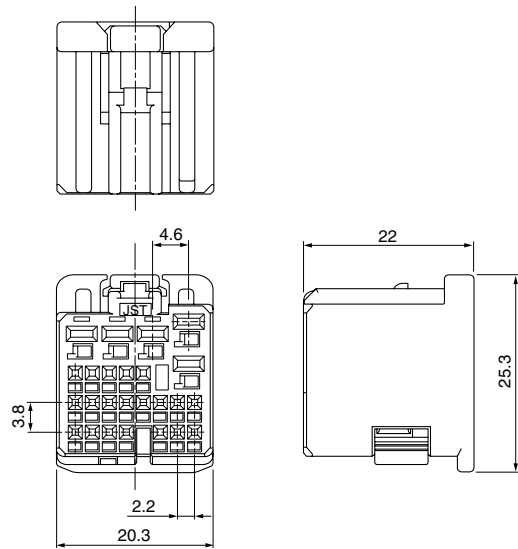

• G Block

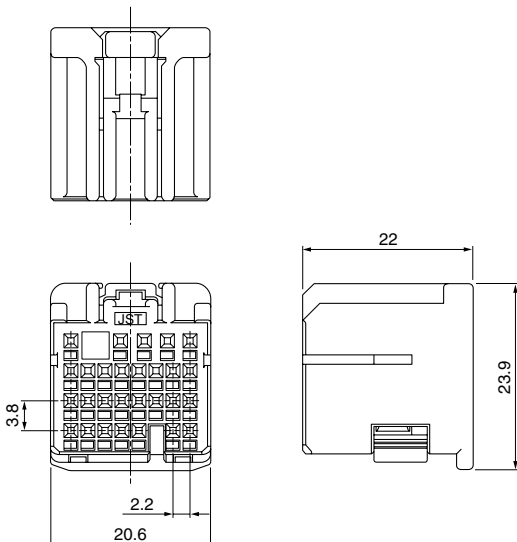

Type	Circuits	Model No.	Q'ty/box	Color	
				Housing	Retainer
A Block	27	HITPB-27-A-LM	336	Light green	Blue
B Block	25	HITPB-25-B-S	280	Natural (White)	Blue
C Block		HITPB-25-C-LE	280	Light blue	Blue
D Block		HITPB-25-D-K	280	Black	Blue
E Block		HITPB-25-E-N	280	Brown	Blue
F Block		HITPB-25-F-PK	280	Pink	Blue
G Block	28	HITPB-28-G-H	280	Gray	Blue

Material

Housing: PBT
Retainer: PBT

Note: Contact JST for other circuits.

Header

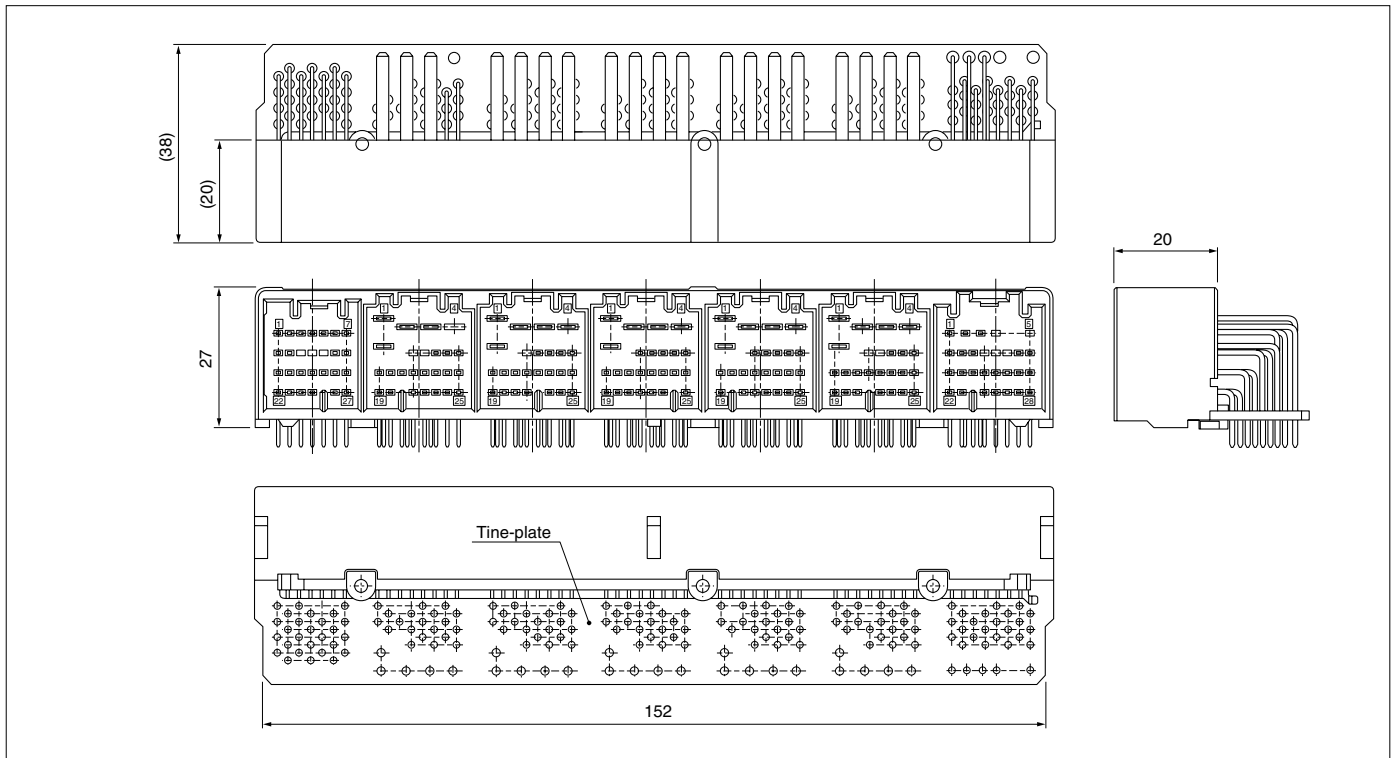

Circuits	Model No.	Q'ty/box
169	S169B-HITHTP-01A	105

Material and Finish

Housing: Glass-filled PBT
 Tine-plate: Glass-filled PBT
 Signal pin: Brass, nickel-undercoated, tin-plated (reflow treatment)
 Power pin: Copper alloy, nickel-undercoated, tin-plated (reflow treatment)

PC board layout

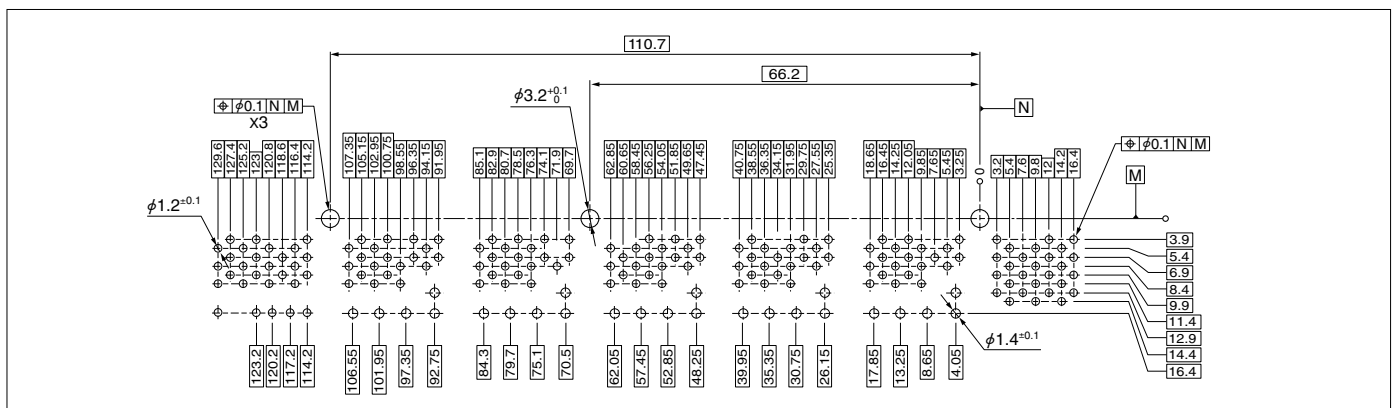

Crimping machine, Applicator, Hand crimp tool

Strip terminal	Crimping machine	Crimp applicator MKS-L		Hand crimp tool
		Dies	Crimp applicator with dies	
SNAC3-A001T-M0.64	AP-K2N	MK/SNAC3-A001-064	APLMK SNAC3-A001-064	—
SNAC3-A011T-M0.64		MK/SNAC3-A011-064	APLMK SNAC3-A011-064	—
SNAC3-A021T-M0.64		MK/SNAC3-A021-064	APLMK SNAC3-A021-064	YRK-1003
SNAC3-A031T-M0.64		MK/SNAC3-A031-064	APLMK SNAC3-A031-064	YRK-1012
SNAC-A061T-M2.8		MK/SNAC-A061-28	APLMK SNAC-A061-28	—
SNAC-A081T-M2.8		MK/SNAC-A081-28	APLMK SNAC-A081-28	—
SNAC-A091T-M2.8		MK/SNAC-A091-28	APLMK SNAC-A091-28	—

Note: When crimping operation is conducted using an applicator and die set other than the above, JST cannot guarantee the performance of the terminal.